

# LW VERSION - 1450 RPM

ITEM	PART No.	KIT	DESCRIPTION	Qty.	MODELS
28	0202.0018.00	C	PISTON Ø18 mm	3	3016 S - 3016 E 3020 S - 3025 S 3513 S - 3513 E 3517 S - 3525 S 2520 S
	0202.0020.00	C	PISTON Ø 15 mm	3	2015 S - 2015 E 2020 S - 2020 E
29	2812.0038.00	C	WASHER	3	
30	1210.0055.00	C-D	O-RING 1,78X 6,07 mm	3	
31	2409.0044.00		PISTON GUIDES	3	
32	3011.0014.00		WRIST. PIN	3	
33	0205.0048.00		CON. ROD	3	2020 S - 2020 E 2015 S - 2015 E 3513 S - 3513 E
	0205.0050.00		CON. ROD	3	3016 S - 3016 E 3020 S - 3025 S 3517 S - 3525 S 2520 S
34	3019.0033.00		SNAP RING Ø 18 mm	1	
35	3201.0010.00		OIL INDICATOR	1	
36	1210.0333.00	D	O-RING 1,78X23,52 mm	1	
37	1210.0206.00	D	O-RING 2,62X101,27 mm	1	
38	0402.0142.00		CRANKCASE COVER	1	
39	3609.0041.00		SCREW M6X25	4	
46	1210.0441.00	D	O-RING 2X14 mm	1	
47	3200.0007.00		CAP 3/8 GAS OT58	1	
48	3200.0007.00		CAP 3/8 GAS OT58	1	
49	2811.0084.00		WASHER 16,7X22X1,5 mm	1	
50	3202.0015.00		CAP G1/2	1	
51	2811.0086.00		WASHER 21,2X27X1,5 mm	1	
61	1220.0030.00		VALVE ASS.BLY.	6	

## S version

ITEM	PART No.	KIT	DESCRIPTION	Qty.	MODELS
40	0019.0094.00	D	OIL SEAL 25X62X10/7 mm	1	
41	3019.0006.00		SNAP RING C72	1	
42	3020.0012.00		SNAP RING C72	1	
43	0438.0071.00		BALL BEARING 25X62X17 mm	1	3025 S - 3525 S
	0438.0075.00		BALL BEARING 25X62X17 mm	1	2015 S - 2020 S 3016 S - 3020 S 3513 S - 3517 S 2520 S
44	1602.0045.00		KEY 8X7X25 mm	1	
45	0001.0290.00		CRANKSHAFT Ø24 mm	1	2015 S - 2020 S 3016 S - 3020 S 3025 S
	0001.0294.00		CRANKSHAFT Ø24 mm	1	3513 S - 3517 S 3525 S
	0001.0333.00		CRANKSHAFT Ø24 mm	1	2520 S

## E version

ITEM	PART No.	KIT	DESCRIPTION	Qty.	MODELS
52	3609.0032.00		SCREW M6 X 20	4	
53	3016.0014.00		FLANGE	1	
54	3607.0015.00		SCREW M8 X 20	4	
55	0019.0075.00	D	OIL SEAL 35X62X7 mm	1	
56	3019.0004.00		SNAP RING Ø 35 mm	1	
57	3020.0012.00		SNAP RING Ø 62 mm	1	
58	2812.0064.00		WASHER	1	
59	0438.0015.00		BALL BEARING 35X62X14 mm	1	
60	0001.0342.00		CRANKSHAFT Ø24 mm	1	2015 E - 2020 E
	0001.0343.00		CRANKSHAFT Ø24 mm	1	3513 E

**COMPLETE VALVE KIT**  
5025.0011.00

**KIT A**

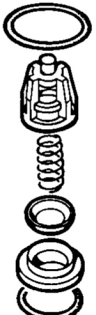

ITEM	PART No.	Qty.
4	1210.0046.00	6
5	3009.0087.00	6
6	3604.0017.00	6
7	1802.0177.00	6
8	1205.0025.00	6
9	1210.0048.00	6

**PISTON SEAL KIT**  
Ø 15 mm 5019.0035.00 - Ø 18 mm 5019.0037.00

**KIT B**

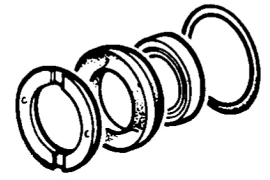

5019.0035.00			5019.0037.00		
ITEM	PART No.	Qty.	ITEM	PART No.	Qty.
20	0009.0196.00	3	20	0009.0193.00	3
21	1241.0034.00	3	21	1241.0035.00	3
22	1241.0030.00	3	22	1241.0028.00	3
24	1210.0223.00	3	24	1210.0223.00	3

**PISTON KIT**  
Ø 15 mm 2409.0071.00 - Ø 18 mm 2409.0072.00

**KIT C**

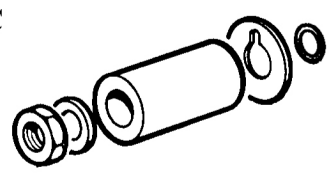

2409.0071.00			2409.0072.00		
ITEM	PART No.	Qty.	ITEM	PART No.	Qty.
26	0600.0048.00	3	26	0600.0048.00	3
27	2811.0080.00	3	27	2811.0080.00	3
28	0202.0020.00	3	28	0202.0018.00	3
29	2812.0038.00	3	29	2812.0038.00	3
30	1210.0055.00	3	30	1210.0055.00	3

5019.0040.00			5019.0041.00		
ITEM	PART No.	Qty.	ITEM	PART No.	Qty.
4	1210.0046.00	6	4	1210.0046.00	6
9	1210.0048.00	6	9	1210.0048.00	6
14	1210.0386.00	1	14	1210.0386.00	1
24	1210.0223.00	3	24	1210.0223.00	3
25	0019.0095.00	3	25	0019.0095.00	3
30	1210.0055.00	3	30	1210.0055.00	3
36	1210.0333.00	1	36	1210.0333.00	1
37	1210.0206.00	1	37	1210.0206.00	1
40	0019.0094.00	1	46	1210.0441.00	1
46	1210.0441.00	1	55	0019.0075.00	1

**SEAL KIT**  
SOLID SHAFT 5019.0040.00  
HOLLOW SHAFT 5019.0041.00

**KIT D**

